

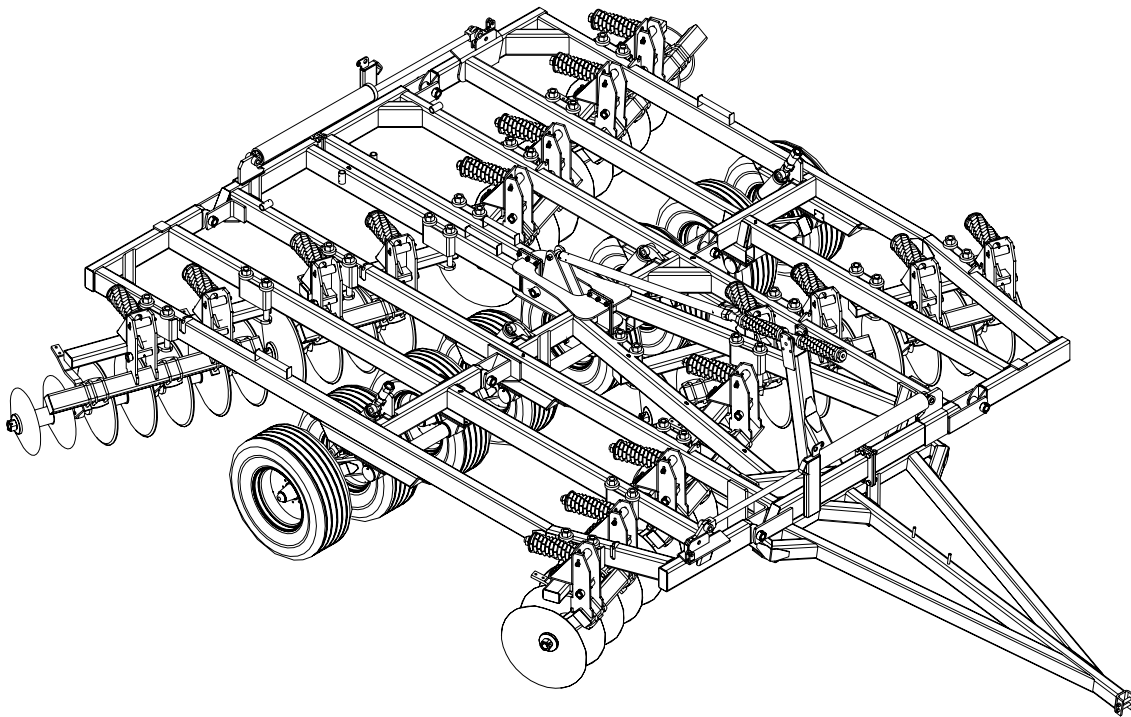

# OFFSET MODELS TANDEM MODELS



OPERATORS  
MANUAL



112 South 2nd Street  
Wishek, ND 58495  
701-452-2449  
[www.wishekmfg.com](http://www.wishekmfg.com)

# WISHEK MFG, LLC

## WARRANTY

Wishek's products are warranted to the original non-commercial purchaser to be free from defects in material and workmanship for a minimum period of twelve (12) months from the original date of purchase.

**Commercial Use:** Warranty for commercial, rental or custom use of any Wishek product is limited to 90 days, parts and labor.

We warrant products sold by us to be in accordance with our published specifications or those specifications agreed to by us in writing at time of sale. Our obligation and liability under this warranty is expressly limited to repairing, or replacing, at our option, within 12 months after date of retail delivery, any product not meeting the specifications. ***We make no other warranty, express or implied and make no warranty of merchantability or of fitness for any particular purpose.*** If requested by us, products or parts for which a warranty claim is made are to be returned transportation prepaid to our factory. Any improper use, operation beyond rated capacity, substitution of parts not approved by us, or any alteration or repair by others in such manner as in our judgment affects the product materially and adversely shall void this warranty. ***No employee or representative is authorized to change this warranty in any way or grant any other warranty.***

Wishek reserves the right to make improvement changes on any of our products without notice.

***When warranty limited or not applicable:*** Warranty on hydraulic hoses, hydraulic cylinders, hubs, spindles, engines, valves, pumps or other trade accessories are limited to the warranties made by the respective manufactures of these components. Rubber tires and tubes are warranted directly by the respective tire manufacturer only, and not by Wishek.

This warranty shall not be interpreted to render Wishek liable for injury or damages of any kind or nature to person or property. This warranty does not include claims for, or extend to the loss or damage of crops, loss because of delay in seeding/planting or harvesting, or any expense or loss incurred for labor, substitute machinery, rental, and transportation expense or for any other reason.

***A Warranty Validation and Delivery Report Form must be filled out and received by Wishek to initiate the warranty coverage.***

### WARRANTY CLAIMS PROCEDURE

1. The warranty form must be returned to Wishek within thirty (30) working days from the repair date.
2. Parts returned to Wishek without authorization will be refused. The parts must be retained at the dealership for ninety (90) days after the claim has been filed. If the Service Department would like to inspect the parts, a packing slip will be mailed to the dealer. The packing slip must be returned with the parts. The parts must be returned prepaid within thirty (30) days of receiving authorization. After the parts are inspected and warranty is verified, credit for the return freight will be issued to the dealer.
3. Parts that will be scrapped at the dealership will be inspected by a Wishek Sales Representative, District Sales Manager or Service Representative within the ninety (90) day retaining period.

# PERSONAL SAFETY IS IMPORTANT!

ALL PERSONNEL INVOLVED WITH THE ASSEMBLY AND/OR OPERATION OF THIS EQUIPMENT MUST BE INFORMED OF PROPER SAFETY PROCEDURES. OPERATOR'S/ASSEMBLY MANUALS PROVIDE THE NECESSARY INFORMATION. IF THE MANUAL IS LOST FOR A PARTICULAR IMPLEMENT, ORDER A REPLACEMENT AT ONCE. OPERATOR'S AND ASSEMBLY MANUALS ARE AVAILABLE AT NO CHARGE UPON REQUEST.

This Safety Alert symbol means **ATTENTION!**  
**BECOME ALERT YOUR SAFETY IS INVOLVED!**

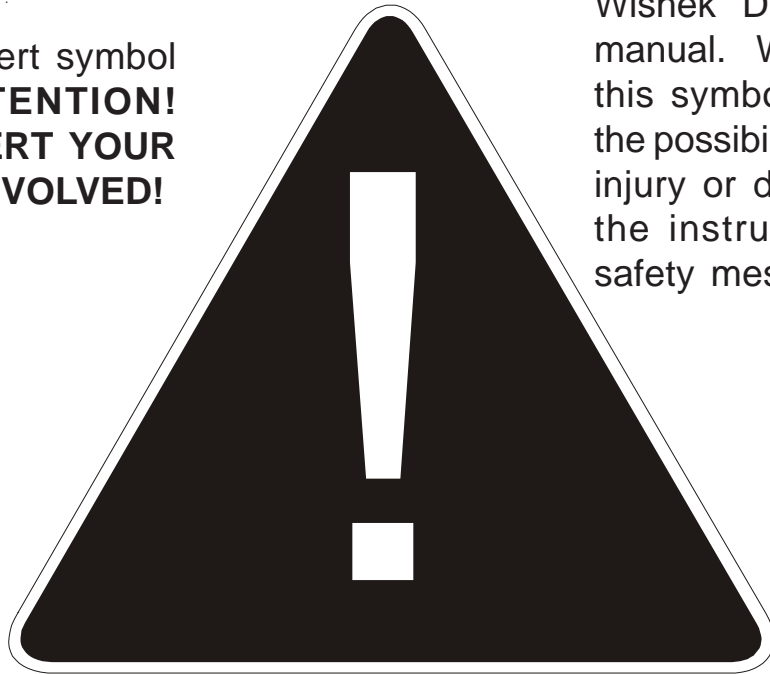

The Safety Alert symbol identifies important safety messages on your Wishek Disc and in this manual. When you see this symbol, be alert to the possibility of personal injury or death. Follow the instructions in the safety message.

## Why is SAFETY important to you?

### 3 Big Reasons

Accidents Disable and Kill

Accidents Cost

Accidents Can Be Avoided

### SIGNAL WORDS:

Note the use of the signal words **DANGER**, **WARNING** and **CAUTION** with the safety messages. The appropriate signal word for each message has been selected using the following guidelines:

### DANGER

An immediate and specific hazard which **WILL** result in severe personal injury or death if the proper precautions are not taken.

### WARNING

A specific hazard or unsafe practice which **COULD** result in severe personal injury or death if the proper precautions are not taken

### CAUTION

Unsafe practices which **COULD** result in personal injury if proper practices are not taken, or as a reminder of good safety practices.

## TO THE OWNER

It is the responsibility of the user to read the Operator's Manual and comply with the safe and correct operating procedures as pertains to the operation, lubrication and maintenance of the product according to the information outlined in the Operator's Manual.

If this machine is used by an employee or is loaned or rented, make certain that the operator(s), prior to operating, is instructed in safe and proper use and reviews and understands the Operator's Manual.

The user is responsible for inspecting his/her machine and for having parts repaired or replaced when continued use of this product would cause damage or excessive wear to the other parts. The word NOTE is used to convey information that is out of context with the manual text; special information such as specifications, techniques, reference information of supplementary nature.

### **MODIFICATIONS**

It is the policy of **WISHEK** to improve its products whenever possible and practical to do so. We reserve the right to make changes, improvements and modifications at any time without incurring obligation to make such changes, improvements on any equipment sold previously.



**THIS SYMBOL USED TO CALL YOUR ATTENTION TO INSTRUCTIONS CONCERNING YOUR PERSONAL SAFETY. BE SURE TO OBSERVE AND FOLLOW THESE INSTRUCTIONS**

	<p><b>WISHEK MFG.</b> WISHEK, NORTH DAKOTA 58495 U.S. PATENT NO. 4396070 CANADIAN PAT. NO. 1181979 PATENTED 1985</p>
<b>MODEL</b> _____	
<b>SERIAL NO.</b> _____	

When in need of parts, always specify the model and serial number. Write this number in the space provided. The serial number plate is located on the main frame front face in the front left corner.

### **PREPARATION**

Before operating the **WISHEK** Disc, a careful inspection must become routine. A check must be made to ensure that all hardware and fasteners are securely tightened and moving parts properly lubricated.

Remove all wires and/or banding material. The parts have been conveniently arranged on the pallet for ease of assembly.

**NOTE:** Always wear safety glasses or goggles and be careful when cutting wires and steel bands as they are under tension and will spring back when cut.

Wherever the terms "left" and "right" are used, it must be understood to mean from a position behind and facing the machine.

Lubricate all bearings and moving parts as you proceed and make sure they work freely.

# **GENERAL INFORMATION**

## **FASTENERS**

Loosely install all bolts connecting mating parts before final tightening.

When tightening bolts, they must be torqued to the proper number of foot-pounds as indicated in the table unless specified. It is important that all bolts be kept tight.

On new machines, all nuts and bolts must be rechecked after a few hours of operation.

When replacing a bolt, use only a bolt of the same grade or higher. Except in shear bolt applications, where you must use the same grade bolt.

Bolts with no markings are grade 2

Grade 5 bolts furnished with the machine are identified by three radial lines on the head.



Grade 8 bolts furnished with the machine are identified by six radial lines on the head.

All U-bolts are grade 5.

## **TIRE INFLATION**

The use of proper air pressure is the most important factor in satisfactory performance and maintenance of implement tires. Underinflation will damage the cord body of the tire and cause a series of diagonal breaks in the fabric sidewall area.

If the tire buckles or wrinkles, the air pressure must be increased to the point where the sidewall remains

	<b>GRADE 2</b>	<b>GRADE 5</b>	<b>GRADE 8</b>			
						
<b>TORQUE IN FOOT POUNDS</b>						
<b>BOLT DIA</b>	3/8	1/2	5/8	3/4	7/8	1
<b>HEX HEAD</b>	9/16	3/4	15/16	1-1/8	1-5/16	1-1/2
<b>UNC GR2</b>	18	45	89	160	252	320
<b>UNC GR5</b>	30	68	140	240	360	544
<b>UNC GR8</b>	40	100	196	340	528	792
<b>UNF GR2</b>	21	51	102	178	272	368
<b>UNF GR5</b>	32	70	168	264	392	572
<b>UNF GR8</b>	48	112	216	368	792	840

Note: Do not inflate tires beyond the specified tire pressure.

## **WHEEL BOLTS**

It is recommended that all wheel bolts be checked for tightness before using and again after one day of use. Check periodically to be sure the wheel bolts are tight.

## **LUBRICATION**

Make sure the disc is properly lubricated. See pages 28-30.

## **HYDRAULICS**

Check wing lift and depth control cylinders for proper alignment and operation. On any machine, check that the hydraulic system has been properly charged and purged.

Remove all wires and/or banding material. The parts have been conveniently arranged on the pallet for ease of assembly.

NOTE: Always wear safety glasses or goggles and be careful when cutting wires and steel bands as they are under tension and will spring back when cut.

Wherever the terms "left" and "right" are used, it must be understood to mean from a position behind and facing the machine.

Lubricate all bearings and moving parts as you proceed and make sure they work freely.

Loosely install all bolts connecting mating parts before final tightening.

When tightening bolts, they must be torqued to the proper number of foot-pounds as indicated in the table unless specified. It is important that all bolts be kept tight. (See Page 5)

On new machines, all nuts and bolts must be rechecked after a few hours of operation.

When replacing a bolt, use only a bolt of the same grade or higher. Except in shear bolt applications, where you must use the same grade bolt.

Bolts with no markings are grade 2

Grade 5 bolts furnished with the machine are identified by three radial lines on the head.

Grade 8 bolts furnished with the machine are identified by six radial lines on the head.

All U-bolts are grade 5.



THIS SYMBOL USED TO CALL YOUR ATTENTION TO INSTRUCTIONS CONCERNING YOUR PERSONAL SAFETY.

BE SURE TO OBSERVE AND FOLLOW THESE INSTRUCTIONS



## CAUTION

**FAILURE TO FOLLOW THESE INSTRUCTIONS MAY RESULT IN PERSONAL INJURY AND/OR EQUIPMENT DAMAGE.**

- Just before and during operation be sure no one is on or around the implement.
- Before activating the hydraulic system, check hoses for proper connections.
- Before lowering the wings for the first time, make sure the entire system has been charged with oil.
- With wings down always install hydraulic cylinder channel lock(s) for transporting.

49165



# TRACTOR REQUIREMENTS

The WISHEK Disc requires approximately 12-16 horsepower per foot. One remote cylinder outlet and control is required for non-winged units. Two remotes are required for winged units.

## WHEELS AND TIRES

Dual tractor rear wheels are recommended for use with the disc. See your tractor's operator's manual for tire inflation and instructions for wheel ballast where required.

## METERING VALVES

The metering valve may be set to provide varying amounts of hydraulic oil flow to the cylinders (see your tractor operator's manual.)

It is recommended the wing lift cylinders run as slow as possible to prevent damage to the implement, persons and property. Turn wing lift hydraulics metering valves to slow position.

## FRONT BALLAST

Tractor front end stability is necessary for safe and efficient operation. Therefore, it is important that the proper amount of weight be installed on the front of the tractor as recommended in your tractor operator's manual.



**Note: Ballast recommendations provide for adequate transport stability at recommended speeds. Additional front ballast may be required for satisfactory field operation due to sudden or extreme forces on the tandem disc. These forces may occur when removing the disc from the ground and turning at rows end, or during field transport over very rough ground.**

## TRANSPORTING

A SMV (Slow Moving Vehicle) emblem **must** be used at all times while traveling on public roads.

The implement must always be placed in transport position and the cylinder channel locks used when traveling on public roads. Never depend on your tractor's hydraulic system to carry the weight while transporting.



**Note: Use extreme caution when working around overhead power transmission lines.**

**Note: Always install lock channels in the center frame lift cylinders for road transport.**

Reduce speed when cornering and when traveling over rough and/or uneven ground. Drive at a reasonable speed to maintain complete control of the machine at all times.

Comply with your state and local laws governing highway safety when moving machinery on a highway.

## BEARING ASSEMBLIES

**IMPORTANT: The spindle nuts on the wheel assemblies are preset at the factory.**

Road transport and field working will seat the bearings and will require additional adjustment. After 20 hours of machine operation remove the grease cap and check the bearing tightness.

Remove the cotter pin and rotate the tire while tightening the spindle nut. Tighten until the drag on the tire stops the rotation. Locate the cotter pin hole in the spindle and loosen the spindle nut just enough to allow insertion of the cotter pin. Replace cotter pin and grease cap.



**YOU are responsible for SAFE operation and maintenance of your Wishek Disc. YOU must ensure that anyone who is going to operate, maintain or work around the disc be familiar with the operating and maintenance procedures and related safety information contained in this manual. This manual will take you step by step through your working day, alerts you to all good safety practices that should be adhered to while operating this equipment.**



Remember, YOU are the key to safety. Good safety practices not only protect you but also the people around you. Make these practices a working part of your safety program. Be certain that EVERYONE operating this equipment is familiar with the recommended operating and maintenance procedures and follows all safety precautions. Most accidents can be prevented. Do not risk injury or death by ignoring good safety practices.

Disc owners must give operating instructions to operators and employees before allowing them to operate the disc, and at least annually thereafter per OSHA regulation 1928.57.

The most important safety device on this equipment is a safe operator. It is the operator's responsibility to read and understand ALL Safety and Operating instructions in the manual and to follow them. All accidents can be avoided.

A person who has not read and understood all operating and safety instructions is not qualified to operate the machine. An untrained operator exposes themselves and bystanders to possible serious injury or death.

Do not modify the equipment in any way. Unauthorized modifications may impair the function and/or safety and could affect the life of the equipment.

Think SAFETY! Work SAFELY!

## **GENERAL SAFETY BEFORE OPERATING**

Read and understand the operator's manual and all safety signs before operating, maintaining or adjusting the disc.

Review safety related items with all operators annually.

Use extreme care when making adjustments.

When working under or around the machine, always lower the disc to the ground.

After servicing, install and properly secure all shields and guards before operating. Remove all tools, parts, and service equipment from the machine.

Have a first-aid kit available for use should the need arise and know how to use it.

Have a fire extinguisher available for use should the need arise and know how to use it.

Clear the area of people and remove foreign objects from the machine before starting and operating.

Always wear relatively tight and belted clothing to avoid entanglement in moving parts. Wear sturdy, rough-soled work shoes and protective equipment for eyes, hair, hands, and head. Wear suitable ear protection for prolonged exposure to excessive noise.

Stop tractor engine, place all controls in neutral, set park brake, remove ignition key and wait for all moving parts to stop before servicing, adjusting, repairing or unplugging. Do not attempt to remove any obstruction while machine is in motion.

## HYDRAULIC SAFETY

Always place all tractor hydraulic controls in neutral before dismounting.

Make sure that all components in the hydraulic system are kept in good condition and are clean.

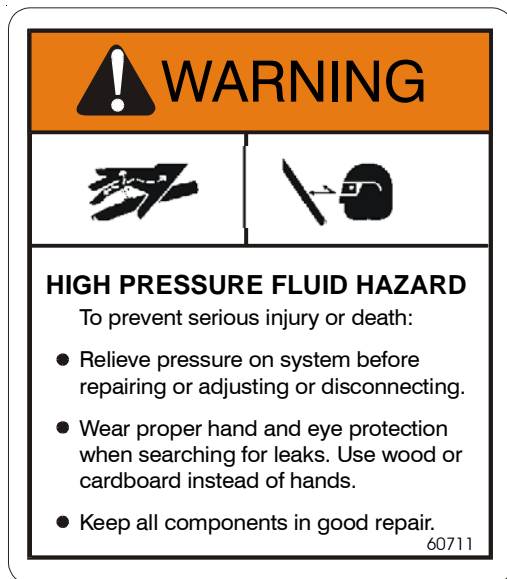

Relieve pressure before working on hydraulic system.

Replace any worn, cut, abraded, flattened or crimped hoses and metal lines.

Before applying pressure to the system, make sure all components are tight and that lines, hoses and couplings are not damaged.

Do not attempt any makeshift repairs to the hydraulic lines, fittings or hoses by using tape, clamps or cements. The hydraulic system operates under extremely high-pressure. Such repairs will fail suddenly and create a hazardous and unsafe condition.

Wear proper hand and eye protection when searching for high pressure leaks. Use a piece of cardboard as a backstop instead of hands to isolate and identify a leak.

If injured by a concentrated high-pressure stream of hydraulic fluid, seek medical attention immediately. Serious infection or toxic reaction can develop from hydraulic fluid piercing the skin surface.

## STORAGE SAFETY

Store unit in an area away from human activity.

Do not permit children to play around the stored unit.

Store in a dry, level area with wings folded down and transport locks installed. Support the base with planks if required.

## TIRE SAFETY

Failure to follow proper procedures when mounting a tire on a wheel or rim can produce an explosion which may result in serious injury or death.

Do not attempt to mount a tire unless you have the proper equipment and experience to do the job.

Have a qualified tire dealer or repair service perform required tire maintenance.

## TRANSPORT SAFETY

Read and understand ALL the information in the Operator's Manual regarding procedures and SAFETY when moving the disc in the field, yard or on the road.

Check with local authorities regarding transportation on public roads. Obey all applicable laws and regulations.

Always travel at a safe speed. Reduce speed and use caution when making corners or meeting traffic.

Make sure SMV (Slow Moving Vehicle) emblem and all lights and reflectors that are required by the local highway and transport authorities are in place, are clean and can be seen clearly by all overtaking and oncoming traffic

Use a drawbar pin with provisions for a mechanical retainer.

Attach a safety chain before moving (see safety chain information.)

Always transport with wing lock pins in and lift cylinder locks installed.

Always use hazard warning flashers on tractor when transporting unless prohibited by law.

Do not allow riders.

Do not exceed 20 m.p.h. during transport.

## SMV

The SMV emblem is to be secured as near to the rear and centered, or as near to the left center of the implement as possible.

The bracket provided is designed to mount to numerous frame sizes and can be orientated in numerous positions to avoid interference with implement componenets.

Emblem is to be 2 to 6 feet above the ground measured from the bottom edge of the emblem.

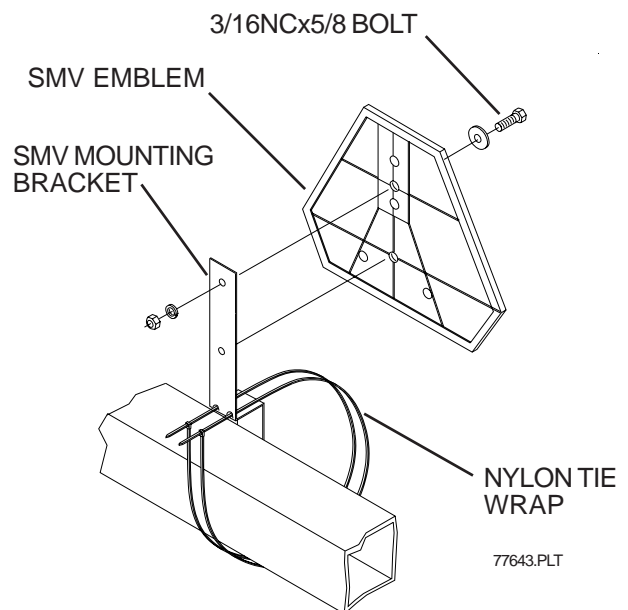

Keep safety decals clean. Replace any safety decals that are damaged, destroyed, missing, painted over or can no longer be read. Replacement safety decals are available through your dealer.

# SAFETY DECALS

## SAFETY CHAINS

The purpose of the safety chain is to provide an auxiliary attaching system to retain the connection between towing and towed machine in the event of separation of the primary attaching system.

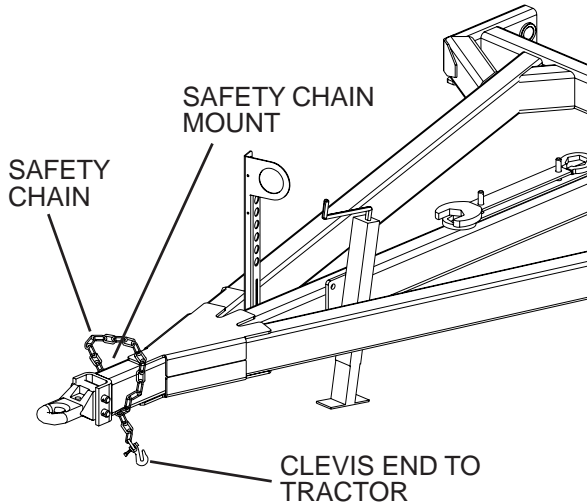

The safety chain should be hooked long enough to permit full turns. Unnecessary slack should be taken up.

The intermediate support is to be used if there is more than 6" of unsupported chain on either side of the primary attaching point.

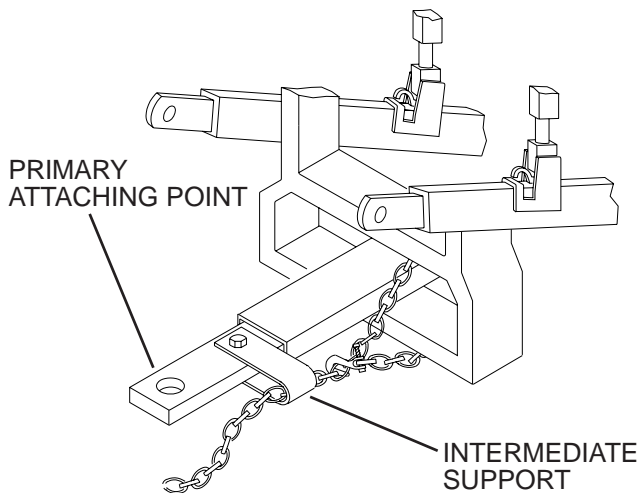

The intermediate support must not be mounted more than 6" from the primary attaching point (see illustration below.)

Safety decals appear at various locations on your machine. These decals are provided for your safety, your family's safety and your employee's safety. Replace any decal that becomes worn, damaged, painted over or difficult to rear.

Keep safety decals and signs clean and legible at all times.

Replace safety decals and signs that are missing or have become illegible.

Replaced parts that displayed a safety sign should also display the current sign.

Safety decals or signs are available from your Dealer Parts Department.

### How to install Safety Decals:

Be sure that the installation area is clean and dry.

Decide on the exact position before you remove the backing paper.

Remove the smallest portion of the split backing paper.

Align the decal over the specified area and carefully press the small portion with the exposed sticky backing in place.

Slowly peel back the remaining paper and carefully smooth the remaining portion of the decal in place.

Small air pockets can be pierced with a pin and smoothed out using the piece of decal backing paper.

### Serial Plate

To insure efficient and prompt service please furnish us with the model and serial number of your Wishek disc in all correspondence or other contacts. The serial plate is located on the front face of the center frame.

## STANDARD EQUIPMENT - *varies by model*

6x4, 8x4, or 6x12 Framework  
214 Series and 315 series Relube gang bearings  
Tapered leveling blades  
1-15/16" or 2-3/4" Round gang shaft  
Hitch Jack  
Hydraulic hose carrier  
Transport channel lock  
Hydraulic system with manifold hoses to the tractor.  
Adjustable blade scrapers  
Constant level spring loaded leveling adjustment  
Cast Iron hitch  
Gang shaft wrench and U-bolt wrench  
6-bolt, 8-bolt, or 10bolt hubs

## Blade size/spacing - *varies by model*

22" blades on 9" spacing  
24" blades on 10" spacing  
28" blades on 11" spacing  
30" blades on 13" spacing  
32" blades on 13" spacing  
36" blades on 18" spacing

## OPTIONAL EQUIPMENT

- Leveling Harrow Attachment
- Hydraulic Disc Leveler
- Notched Blades
- 10-bolt Mainframe Hubs (26ft and up)

## GENERAL FEATURES

Your Wishek disc features a constant-level, spring loaded leveling adjustment that keeps the disk at a level position at all soil depths and when in the transport position.

Tandem models feature front gangs are offset and overlapped to make a complete cut. The rear gangs are spaced to leave a level field. Wings are supported by wide-spaced flotation tires which allow maximum response to uneven ground. Winged models will flex 5° up or down.

## HYDRAULIC CYLINDERS

The hydraulic components received with your disk were selected to deliver the most efficient and economical use. Any parts for replacement should be replaced with parts of the same type and size. Replace any hoses or fittings which develop leaks

Standard equipment for your disc includes all hydraulic cylinders, fittings, and hoses from the cylinders to the tractor. The main lift cylinders are provided with O-ring ports. The wing fold cylinders have O-ring ports. Hoses and fittings are provided that attach to these cylinders. The remaining fittings and hose ends are "JIC" fittings (**not pipe thread**) except the 1/2" male pipe fitting at the end of the hose leading to the tractor.

The lifting system uses (2) 4"x 12" cylinders on rigid models, or (2) 4.5"x12" & (2) 4"x12" phasing type cylinders on folding models. The wing folding system uses either (2) 5" bore x 36" stroke cylinders, or (4) 5" bore x 36" stroke cylinders, depending on size.

# SAFETY DECALS PLACEMENT - ALL MODELS

The SMV (Slow Moving Vehicle) Emblem is a recommended attachment that should be added to the rear of the disc. When transporting the disc over public roads, the SMV Emblem must be used, for protection of tractor and motor vehicle operators.

**\* SEE PAGE 15  
FOR DECAL  
PART NUMBERS**

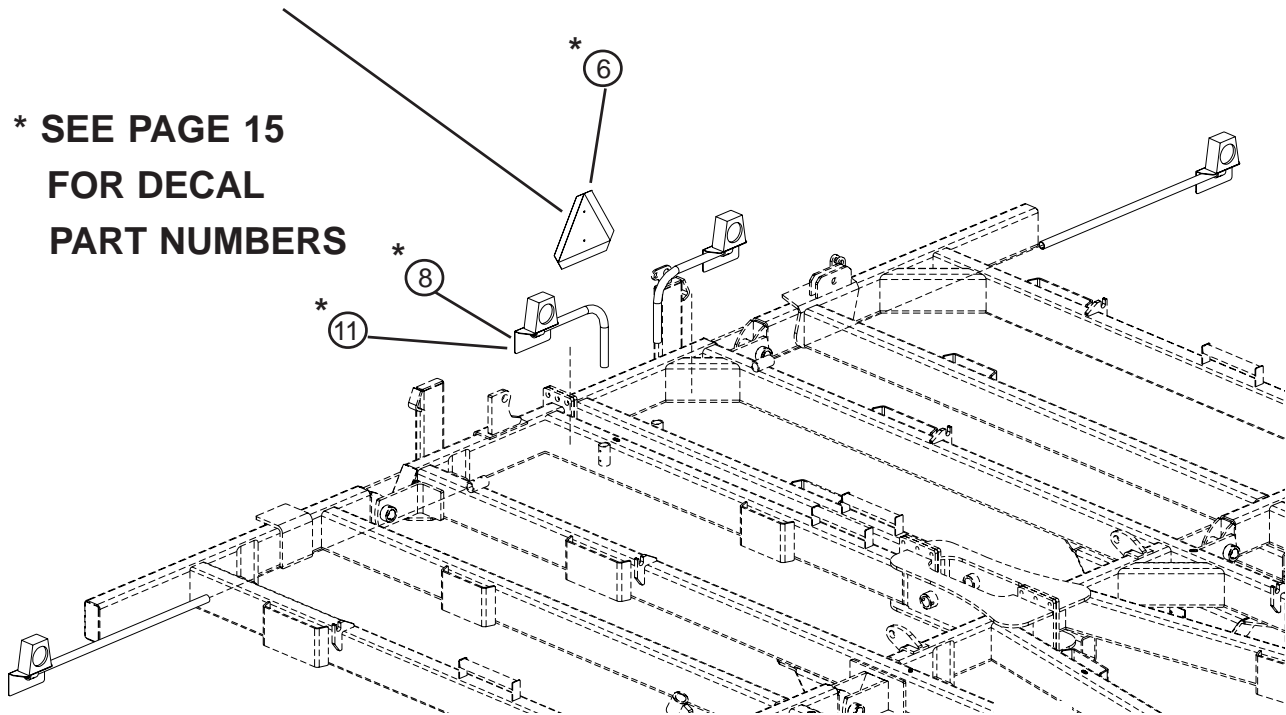

**NOTE:** Replace any safety decals that become worn or difficult to read; replace all safety decals when repainting.



**CAUTION:** When trailing the disc on public roads the SMV Emblem must be used, for protection of tractor and motor vehicle operators.



**CAUTION:** When transporting machinery over public roads, comply with your local and state laws regarding length, width, and lighting.

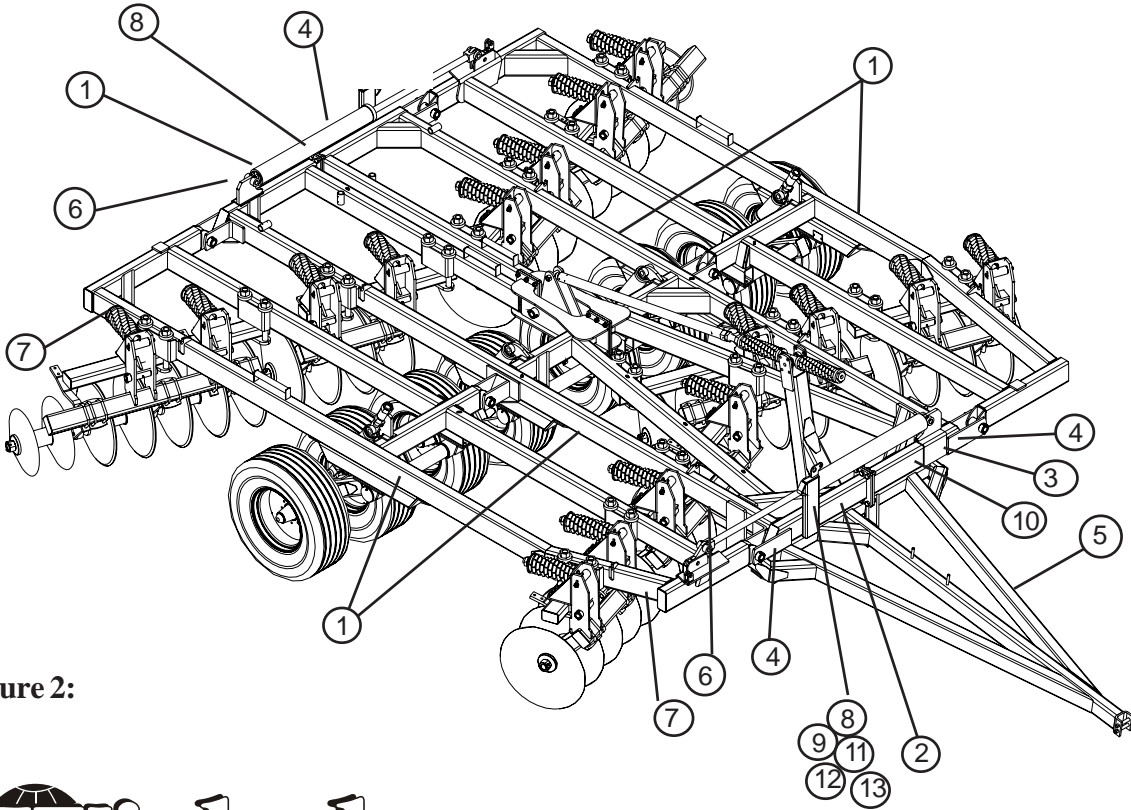

Figure 2:



1 - 243346 - Wishek Decal



3 - 997263 - Decal Promotes



5 - 9971163 - Decal Safety Set



7 - 22372 - Amber Reflector



9 - 997860 - Decal Read Manual



11 - 997862 - Decal Voltage



13 - 9971018 - Decal Speed

2 - Model Decal



4 - 997864 - Decal Lockout Warning

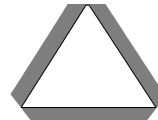

6 - 41345 - SMV Kit



8 - 997994 - Decal Lock Pins



10 - Serial Number Plate Location



12 - 997854 - Decal Folding

# GENERAL OPERATING INSTRUCTIONS - ALL MODELS



## WARNING

1. BEFORE OPERATING - STUDY OPERATORS MANUAL, SAFETY MESSAGES AND SAFE OPERATING PROCEDURES, READ SAFETY SIGNS ON THIS MACHINE.
2. TRANSPORT ON PUBLIC ROADS - OBSERVE FEDERAL, STATE AND LOCAL REGULATIONS; DISPLAY SMV EMBLEM; ATTACH PROPER STRENGTH IMPLEMENT SAFETY CHAIN; AND LIMIT MAXIMUM SPEED TO 20MPH (32 km/h)
3. LOWER OR BLOCK ALL ELEVATED COMPONENTS BEFORE SERVICING OR LEAVING THIS MACHINE.

For economical and efficient operating, the operator must be aware of all the adjustments which should be considered for the best results. The operator should know what adjustments must be made for different conditions.

## HITCHING INSTRUCTIONS

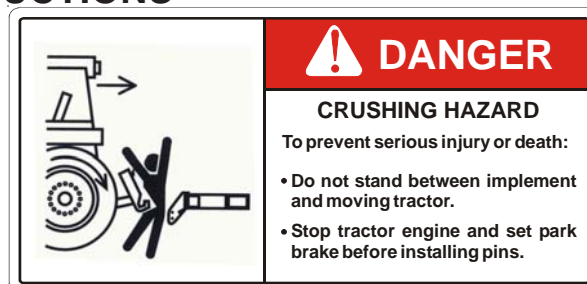

## JACK

The Wishek disc is equipped with a dropleg jack. (See Fig. 3)

To operate the jack, turn handle clockwise to extend and counter-clockwise to retract.

Refer to next page for jack shown in operating position.

Figure 3:

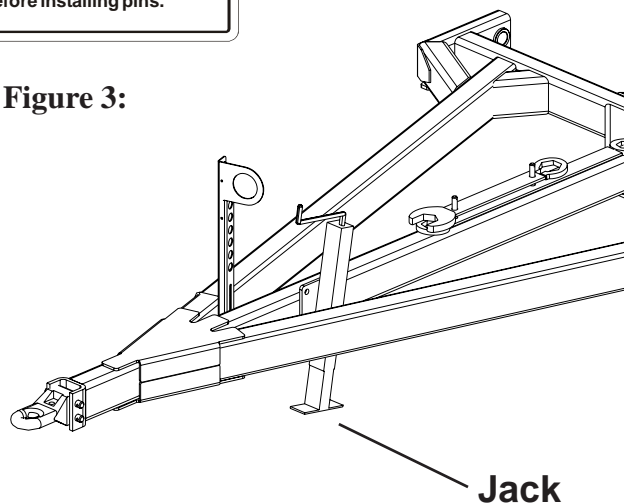



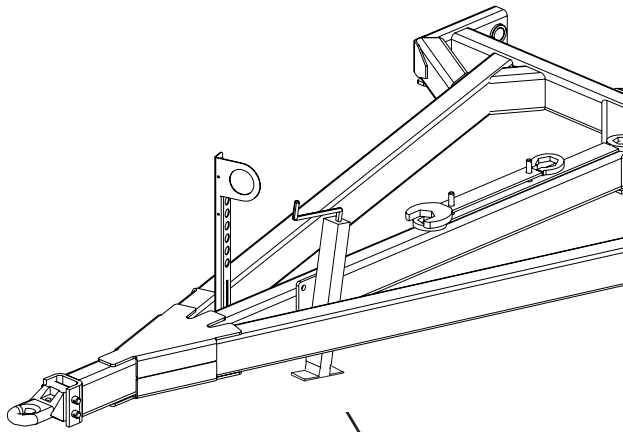

### Jack Transport Position

Figure 4:

The jack is shown here in the transport position.

(See Figure 4)



**CAUTION:** Before placing the jack into transport position, the hitch clevis should be secured to the drawbar to prevent the hitch from falling to the ground.

**IMPORTANT:** When working the disc, jack should be in transport position.

## HITCH PIN

The recommended hitch pin size is at least 2" in diameter and should be securely attached so that the pin can not inadvertently come out.



**CAUTION:** Park or block the disc so it will not roll when disconnected from the tractor drawbar.

## HYDRAULIC FITTINGS

All fittings for the hydraulic hoses are provided including Pioneer Quick Couplers to the tractor. The operator will need to furnish the hydraulic couplers, if Pioneer Quick Couplers provided aren't a match.



**CAUTION:** Do not connect or disconnect hydraulic components when there is pressure within the system. Hydraulic systems are highly pressurized. Escaping hydraulic oil, even an invisible pinhole leak, can penetrate body tissues and cause serious injury. Use a piece of wood or cardboard when looking for leaks. Never use the hands or other parts of the body. When reassembling, make absolutely certain that all connections are tight. If injured by hydraulic oil escaping under pressure, see a doctor immediately. Serious infection or reaction may occur if medical attention is not received at once.

# **TOWING INSTRUCTIONS - ALL MODELS**



**CAUTION:** Observe safe driving practices; comply with your local and state laws regarding length, width, and lighting. Be aware of low and narrow passages both in the field and on the road.

**Figure 5:**

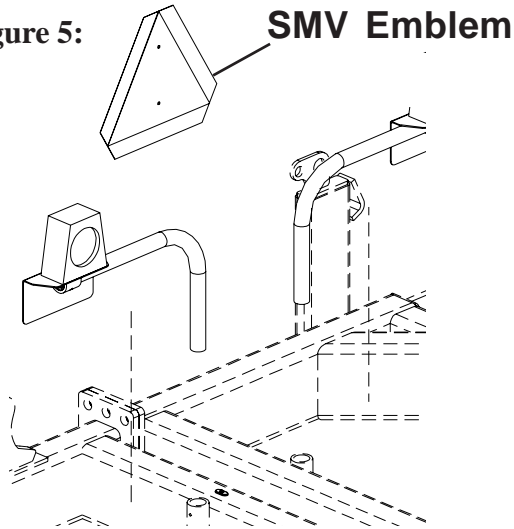

## **SMV EMBLEM**

When trailing the disc on public roads, the SMV emblem must be used, for protection of tractor and motor vehicle operators. (See Figure 5)

## **TRANSPORT LOCKOUT**

When transporting or working on the machine in the raised position, the channel lock must be used to prevent the machine from falling in case of a hydraulic component failure. The lockout is secured with a lynch pin. (See Figure 6)

**Figure 6:**

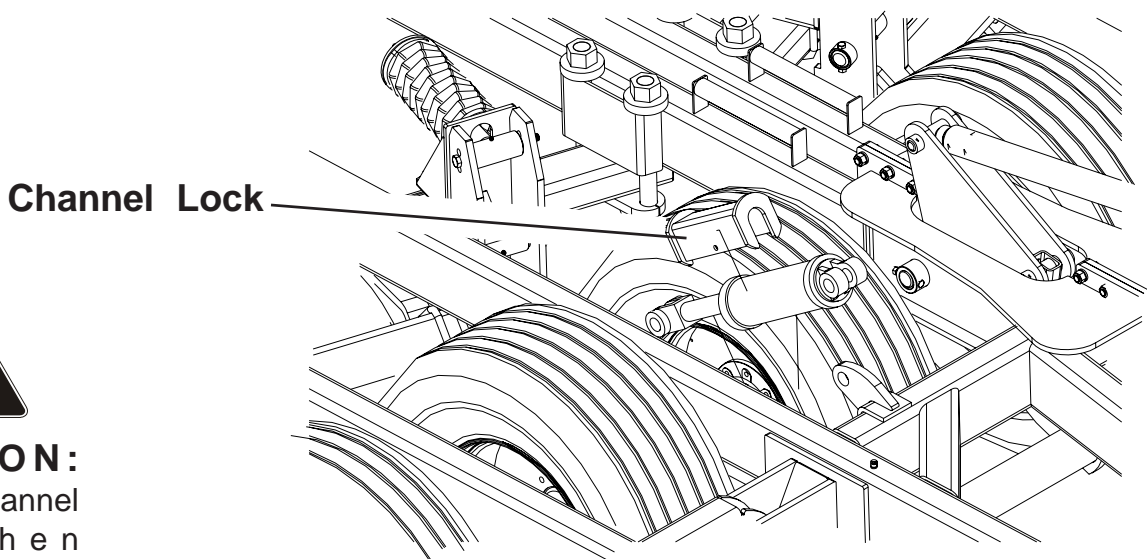

**CAUTION:**  
Secure channel  
Lock when  
transporting.

## WING LIFT CIRCUITRY - FOLDING MODELS

**WISHEK** Discs equipped with folding wings have hydraulic wing lift cylinders to fold the implement for road transport.

Fig. 7 shows a simple two (2) cylinder circuit used to fold Wishek Discs with a single pair of folding cylinders. Larger size discs use two pair of folding cylinders attached parallel.

When lowering the wings, hold the hydraulic control lever until cylinder wing linkages (pull-up dogs) are in mid-stroke. If possible, operate wing hydraulics in float position.

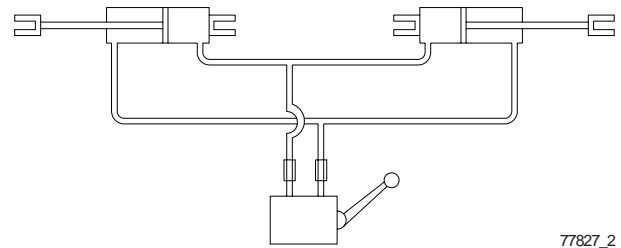

77827\_2

**Figure 7:**

Fold the main wings until they contact the wing rest.

# DEPTH CONTROL CIRCUITRY - FOLDING MODELS

Folding units are equipped with a lift system that utilizes phasing cylinders. In a phasing system the cylinders are sized to operate in series and provide a level lift to the unit. The Wishek phasing system utilizes equal length cylinders, while varying the bore. On this unit the center frame cylinders have a 4.5" bore diameter with a 4" bore wing cylinder. See Fig. 8.

The cylinders are connected in series with the rod end of the center frame cylinders connected to the base end of the wing cylinders.

To accomplish proper phasing, it is necessary to hold lever in raised position for a few seconds to purge air from system.

After oil has "rephased" the system, leave depth control in neutral position at least three seconds to allow the cylinders to settle far enough to close the rephase passages and completely rephase the system.

**Note: This system requires periodic raising of the unit and holding of the tractor valve to expel air or contaminants**

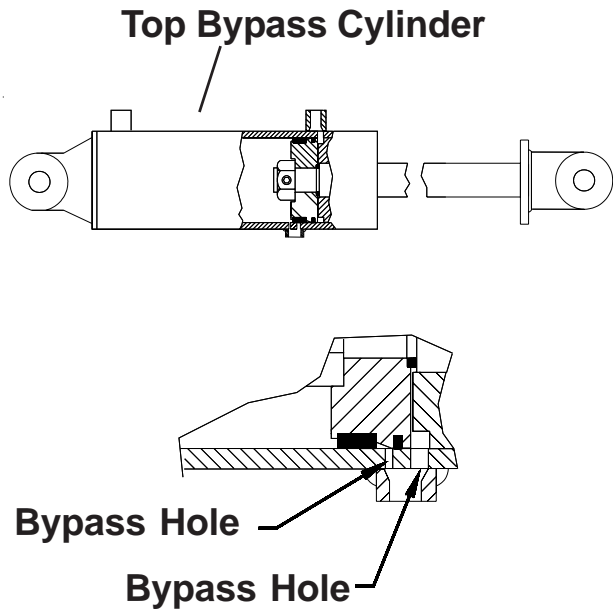

**Note: To phase or re-phase the system, the tractor control valve must be held in the raised position until the entire implement is raised and any air that may be in the lines has been expelled.**

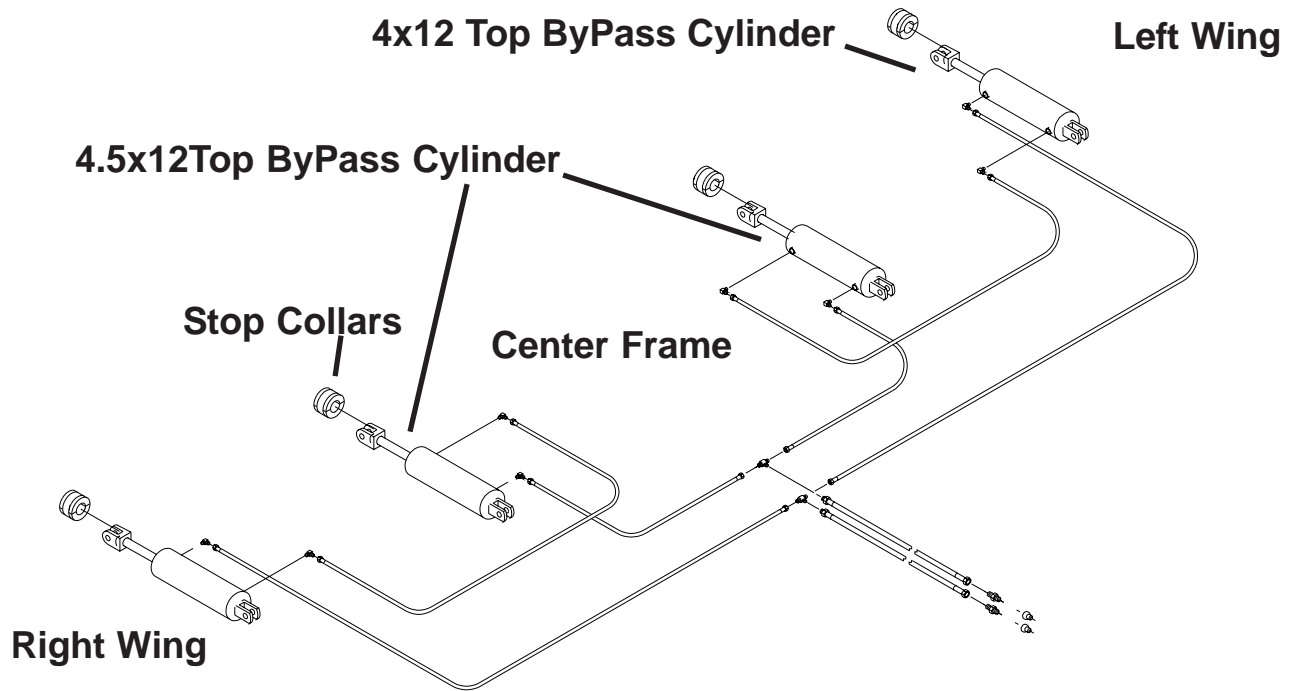

Figure 8:

## DEPTH SETTING

To ensure even field depth across width of unit, cylinder stops will need to be used on all lift cylinders.

If further leveling of the unit is required, you will need to adjust the wing cylinder lollipop to raise the wing.

# FRONT WING LOCKOUT - FOLDING MODELS

The front wing lockouts should be used whenever the wings are in a folded position.

To lock wings, place wing lock pin through ears of wing rest and the clevis on the wing (see figure 9) and place hair pin through pin. It is important that the hair pin be placed securely on hitch pin to prevent pin from falling out. When wing is unfolded the pin can be stored in its holder to prevent loss. The holder is located on the same ear as the locking location.

Figure 9:

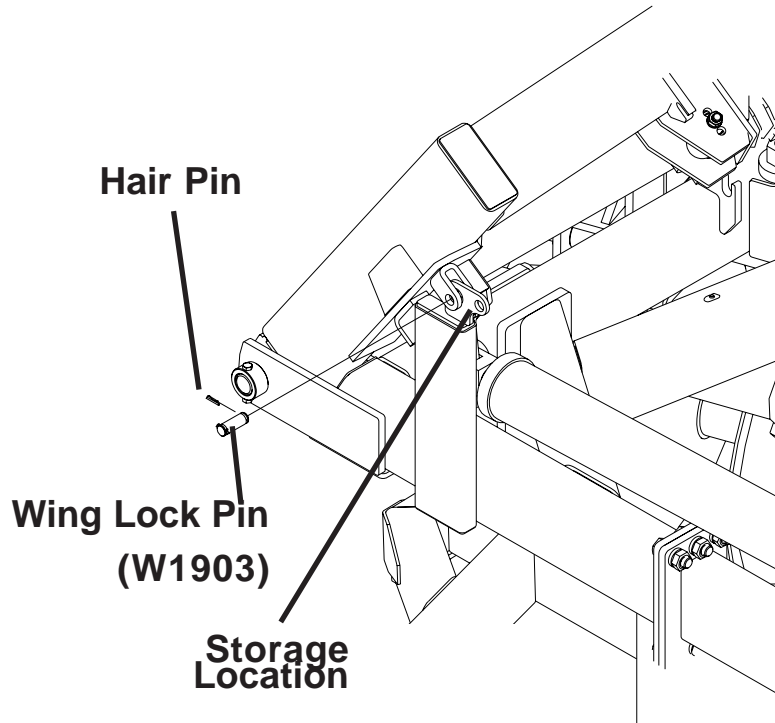

**CAUTION:** Do not stand or work under disc wings unless wing lock pins are installed. Accidental

operation of hydraulic lever or failure of any hydraulic components could cause disc wing to drop.

	<p><b>DANGER</b></p> <p><b>STAND CLEAR AT ALL TIMES</b></p>	<ul style="list-style-type: none"><li>• Never walk or stand in the path of the wings.</li><li>• Completely lower wings before performing service or adjustments.</li><li>• Failure to do so will result in serious injury or death.</li></ul> <p><small>222800</small></p>
---	---	--

## ADJUSTMENT FOR LEVELING -ALL MODELS

Different depth settings for front and rear gangs can be used to achieve the desired results. This adjustment will vary depending on soil conditions. The tension on the cushion springs is preset at the factory to allow the disc to flex when going over dead furrows or other uneven land. To lock the leveling screw, use the jam nut. (See Figure 11)

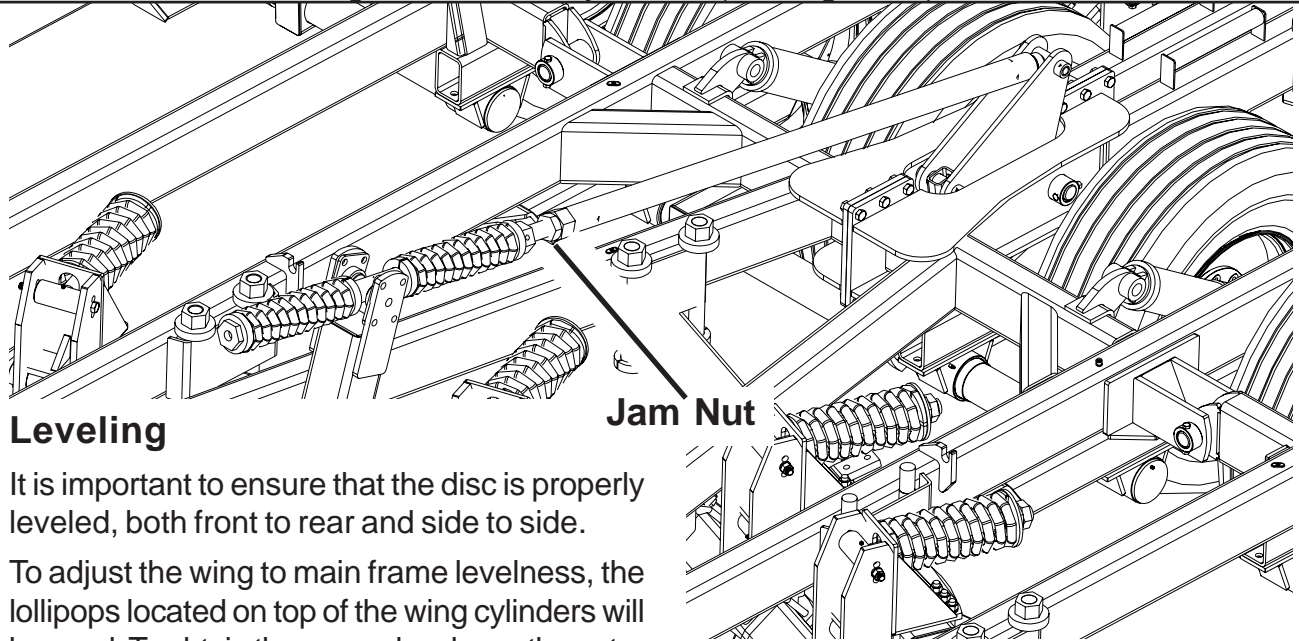

### Leveling

It is important to ensure that the disc is properly leveled, both front to rear and side to side.

To adjust the wing to main frame levelness, the lollipops located on top of the wing cylinders will be used. To obtain the proper levelness the outer most front blade on each wing should be about 1/2" below the center blades.

To adjust the front to back levelness of the disc, the leveling screw that attaches the hitch to the axle will need to be adjusted. For proper initial adjustment, the front gang should contact the ground slightly before the rear gang when lowering.

### SCRAPER ADJUSTMENT

The steel scrapers provide a continuous cleaning action when properly adjusted. It is important that the clearance be checked daily under normal soil tilling conditions and more often in extremely trashy disking.

Each scraper may be adjusted by loosening the U-bolts and sliding the assembly along the scraper bar. (See Figure 12)

### SCRAPER GAP SETTINGS

(scraper to blade distance)

**Standard/Spool** - 1/8in

**Bearing Stand**- Concave: 1/8in, Convex: 3/4in

**Rotary** - Lower 2/3 of disc lightly contact blade

Figure 11:

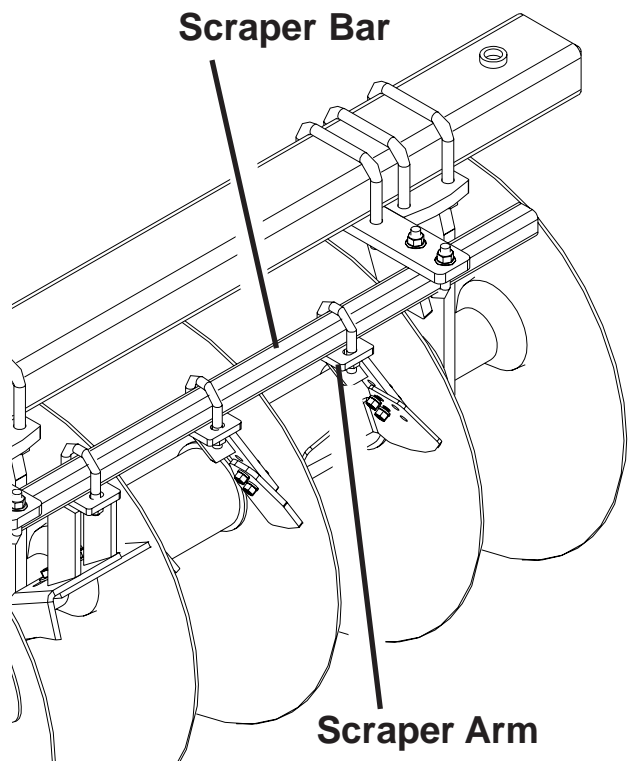

Figure 12:

## **FIELD SETTING - ALL MODELS**

Even if the unit has been leveled in the yard, it should never be assumed that the unit would operate level in the field without checking or adjustments. Changing field conditions, loading of the blade and attachments will impact the functional level and working in the field.

Move to the field and stop the unit in a level area. Unfold the wings, if folding model; making certain that there is adequate room, with no person or obstruction in the wing fold area. Remove and store the wing lock pins. Activate the main lift hydraulics, and remove the transport channel locks from the main lift cylinders.

Make a visual inspection of the unit to ensure that all hardware is properly tightened, hoses are clear and that the unit is ready for field operation.

Stop collars should not be installed. Cycle the main lift hydraulics a few times to purge any air from the system, then install stop collars.

Once the main frame has been leveled by adjusting the leveling screw, move into the field at operational depth and stop the unit. Measure the frame height of the wing at the rear of the wing and compare to the frame height at the main frame. Adjust the wing eye bolt screw to level the wing to the main frame. Repeat the same procedure for the opposite wing.

### **OPERATING SPEED**

Best results will be achieved when operating speed of 4.5 to 5.5 miles per hour is maintained. Speed may need to be varied to achieve proper finish of field. High speed will increase the chance of damage to the machine, when striking foreign objects such as rocks or stumps.

Lift machine out of the ground when making turns. This avoids serious ridging and high stresses on the machine.



# **MAINTENANCE/LUBRICATION**

**REMEMBER:** Accidents don't always happen to the other guy, so take great care when performing maintenance.

Periodic preventative maintenance such as tightening bolts, replacing worn pins, and proper lubrication will do much to extend the useful trouble-free of the Wishek Disc and provide the owner with the maximum operational performance.

After two hours and again after the first eight hours of operation the following checks and adjustments should be made.

- 1 Check and tighten, if necessary, all gang shaft nuts. Tighten to at least 2000ft pounds, then to next closest stop bolt. Keyway on gang shaft. NEVER loosen gang shaft nut to set bolt in keyway.
- 2 Tighten all bolts. Especially the bearing stand bolts. Tighten all bolts to torques specified. When bolts are replaced, be sure they are replaced with bolts of equal strength. See bolt head markings on bolt chart. (See Chart on Page 6)
- 3 Check wheel bearings and tighten if necessary. Check and tighten wheel lug bolts.
- 4 Check all pins to see they are securely fastened.
- 5 Check and adjust scrapers. Scrapers should be adjusted according to the scraper adjustment section of this book.
- 6 Lubricate various components that require lubrication. Use Wil-rich 460ep tillage lubricant. (See Pages 28-29)
- 7 Check all hydraulic components and connections for leaks. Replace any hoses or fittings that develop leaks.

Use the above list as a general guide for later checks and adjustments.



**CAUTION:** Never clean, adjust, or lubricate a disc that is in motion.

## GANG BOLT WRENCH

The wrenches, stored on the tongue frame, are useful tools for tightening or loosening gang shaft nuts and gang caster clamps.

**NOTE:** When storing gang wrench on frame use clip provided to hold gang wrenches to the stud on the frame.

## LUBRICATION

For economical and efficient operation, the proper lubrication of the disc is important. The following will detail the parts needing lubrication and the various conditions which determines the time span.

There are eight hubs and spindles that require seasonal lubrication.

The leveling screw has four places which should be lubricated. The top trunion has two and the leveling screw tube has one at the top and one at the bottom. These should be lubricated daily or as necessary. The threads on the leveling screw should be coated with oil occasionally to prevent rust and for a smoother operation.

## Gang Wrenches

Figure 15:

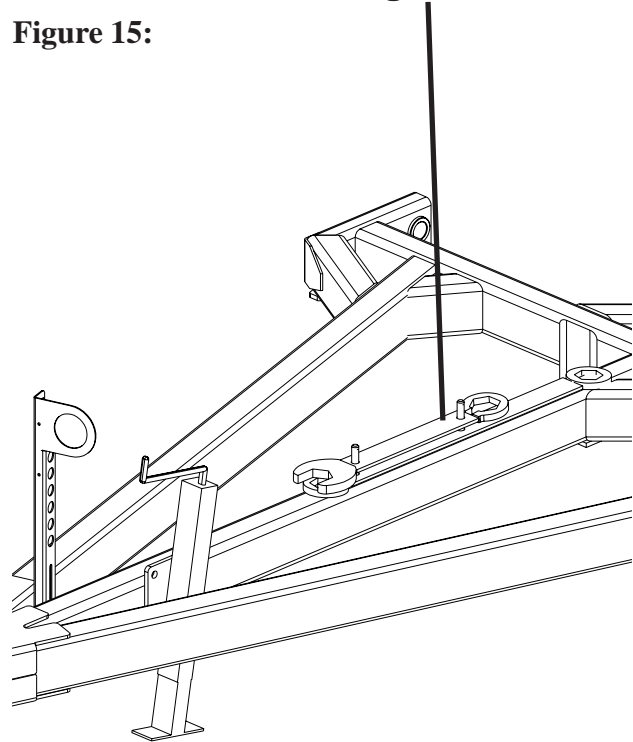

The Bell crank (center triangle) connects the leveling screw to the running gear. There are grease fittings located on the leveling pivot to allow the pivot pins to be greased. These should be lubricated daily during regular use.

All grease fittings excluding gang bearings should be greased daily and at start and end of each season for smooth operation.

**NOTE:** Be sure grease fittings are free of dust and paint before using grease gun. Replace any damaged or missing fittings.

## **GANG BEARINGS**

On the Wishek Disc, the gangs are supported by 214 re-lube gang ball bearings fitted with lubrication fittings. (See Figure 16)

The proper lubrication interval is 6-8 pumps of a handpump grease gun every 80 hours of operation.

There are no bearing adjustments to be made other than to make sure the brackets are firmly fastened.

They should also be lubricated at the start of each season and especially at the end of the season to protect against corrosion during storage.

**Only use a hand grease gun.** Wipe dirt from all grease fittings before lubricating. If a grease fitting is missing, replace it immediately.

### **IMPORTANT**

**LUBRICATE GANG BEARINGS  
USING HAND GREASE GUN ONLY  
6-8 PUMPS EVERY 80 HOURS**

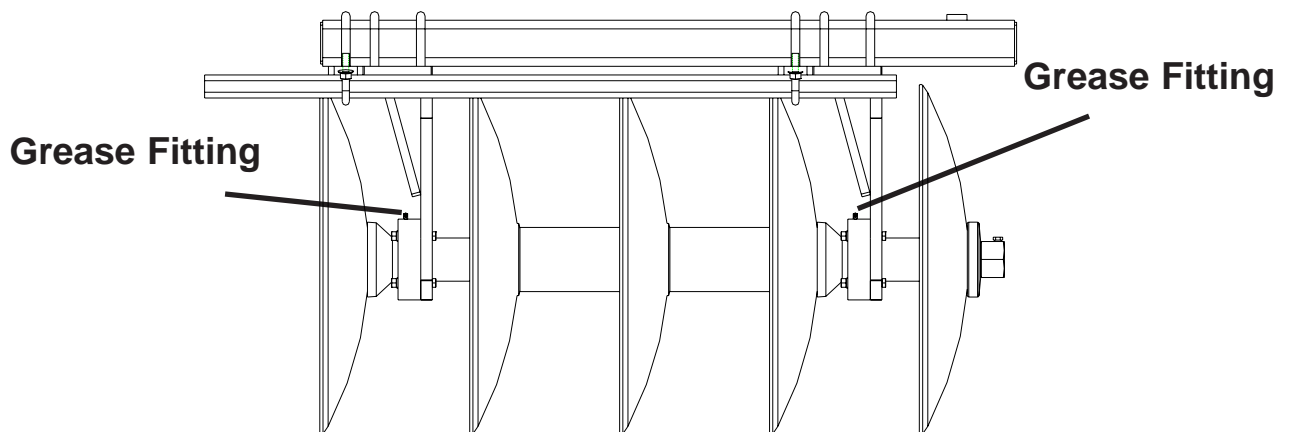
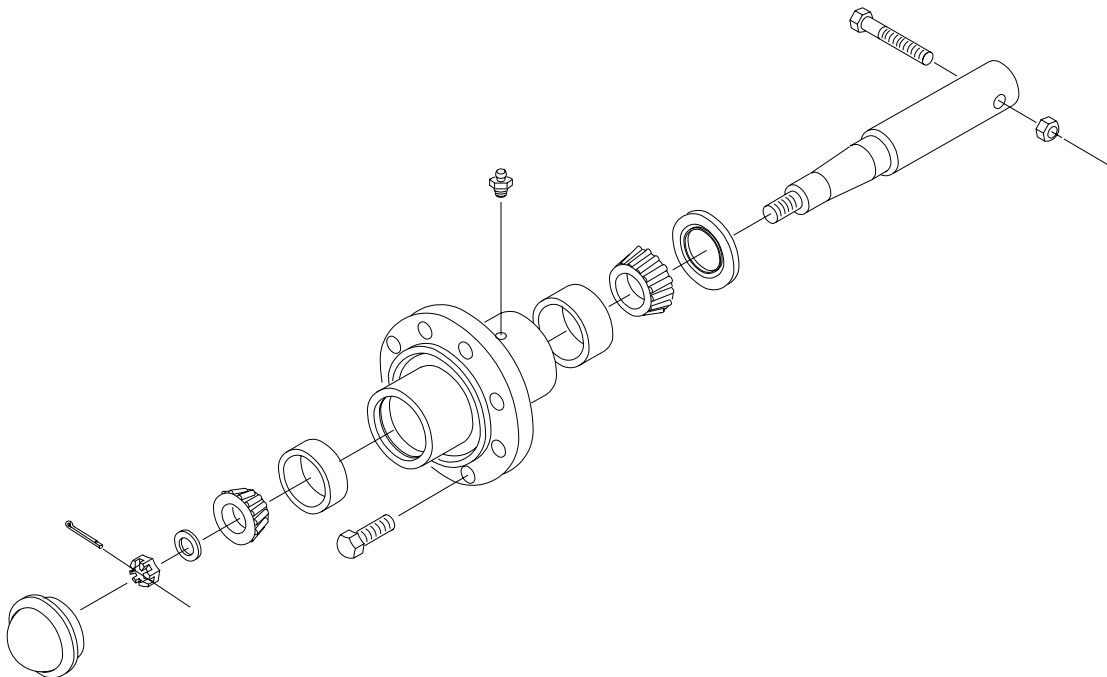

**Figure 16:**

## WHEEL BEARING

It is important that wheel bearings be repacked with grease and adjusted annually. Under hard working conditions, wheel bearings should be inspected more frequently - with occasional checks for excessive end play.

Care must be used in dismantling wheel bearing assembly. First remove the dust cap by prying around the edges. Remove the cotter pin, slotted nut, and flat washer. Carefully remove the hub and bearings from the spindle. Inspect all parts for wear or damage and replace with new parts if necessary.



When reassembling the hub, repack both bearing cones with grease and fill the hub cavity 1/3 full. Place inner bearing assemblies into the hub, and then press grease seal into hub and carefully reinstall the hub on the spindle. When placing hub on spindle be careful not to damage the lip of the grease seal. Install outer bearing assembly into the hub and place flat washer and slotted nut. Then tighten the slotted nut to seal the bearings until the hub lightly binds as you rotate hub by hand. Back off the slotted nut to the next slot and place a new cotter pin in. Use a 3/16"x1-1/2" long cotter pin. Replace dust cap.

Proper storage will add to the life of your disc and assure its being in good condition for the next season. The following procedure is recommended.

Clean off all foreign matter, and thoroughly lubricate disc.

Repaint the disc where the original paint has worn off.

Coat the disc blades and hydraulic cylinder rods with a good rust preventative. Tighten loose bolts and replace any damaged or missing parts

Carefully rotate each gang and check for worn or damaged blades, bent gang shafts, worn scrapers, damaged bearings and other parts which may need replacing.

Whenever disc blades or bearings are replaced, the gang shaft nuts must be torqued to a minimum of 2200 foot pounds. The nut should then be tightened to the NEXT set screw location.

Store in a dry place, with the gangs resting on boards to protect the disc blades and remove weight from the tires. Keep direct sunlight off the tires.

Store with wings down and transport locks engaged.



**CAUTION:** When working on disc, care should be exercised in handling or tightening bolts near disc blades to avoid injury.

## **DISC BLADES MAINTENANCE**

Do **NOT** run machine with loose disc blades. Keep gang bolts tight! Tighten to 2200 foot pounds. Use the gang bolt wrench provided with the machine with a “cheater bar”.

Rust and corrosion are the chief enemies of the disc. Spending a little time and effort protecting the disc blades will reward you with longer service, easier operation, and higher resale value. Dirt and trash will hold moisture, causing rust. Apply a good rust preventative to all land polished surfaces.

If the disc blades, bearings and spools must be replaced on the gang shaft, be sure to keep them in order when removing them so they can be replaced properly. Remember the disc blades on the front gangs must be assembled to throw the soil out. The disc blades on the rear gangs are assembled to throw the soil in. Be careful to place each gang assembly in the same location on the frame from which it was removed.

# **TROUBLE SHOOTING - TANDEM MODELS**

<b><u>PROBLEM</u></b>	<b><u>POSSIBLE CAUSES</u></b>	<b><u>POSSIBLE REMEDY</u></b>
<b>Leaving center ridge.</b>	Excessive speed Rear Gangs cutting too deep and throwing excess dirt to the center Improper gang spacing	Reduce speed Use leveling adjustment reduce rear gang penetration Adjust spacing of gangs at center of machine
<b>Leaving center valley</b>	Discing too slowly Rear gang cutting too shallow Improper gang spacing	Increase speed Use leveling adjustment to increase rear gang penetration Adjust spacing of gangs at center of machine
<b>Gang plugging</b>	Extremely wet field Scraper adjusted improperly or severely worn	Allow to dry if possible or disc shallow once to aid drying time Adjust, service and/or replace scrapers as required
<b>Outside ridging</b>	Wings too deep Front gang too deep and the outside blades digging out more than the rear gangs can bring back Excess speed will also cause outside ridging (throwing dirt out further than the rear gang)	Adjust lollypop connector on wing axles to raise wing Use leveling adjustment to reduce front gang penetration Slow down tractor speed
<b>Cylinder stalling</b>	Hydraulic reservoir low Faulty plumbing Improper connections to tractor Channel lock installed	Add hydraulic oil to reservoir - see tractor manual for type and amount Check the routing of the hydraulic hoses - be sure there is no cross up in the lines Make sure circuits are not crossed at tractor Remove and store channel lock

## TROUBLE SHOOTING - OFFSET MODELS

<u>PROBLEM</u>	<u>POSSIBLE CAUSES</u>	<u>POSSIBLE REMEDY</u>
<b>Disc runs towards the right</b>	Rear Gangs cutting too deep	Lower front end with leveling screw
	Improper gang angle	Increase front gang angle Decrease rear gang angle
<b>Disc runs towards the left</b>	Front gangs cutting too deep	Raise front end with leveling screw
	Improper gang angle	Decrease front gang angle Increase rear gang angle

**NOTE:** Offset discs may be turned to the left with the disc in the ground. However, when turning right, raise disc completely out of the ground.